



WALKER BAY

— 20 YEARS —

20 YEARS AND COUNTING.



For over 20 years, Walker Bay has been designing and building the most innovative, versatile and enjoyable boats on the market. It is our mission to provide our customers with smart, simple, user-friendly solutions so they can fully enjoy being out on the water. We constantly strive to create products that offer better value and fresh thinking, and we take pride in the joy it brings to those who own them.

Walker Bay doesn't just manufacture marine products, we share a passion for boating and a life spent on the water. We stand behind our products, and what's more, we use them. Each product we make goes through extensive design and testing so we can offer a better experience for our customers.

Since 1997 Walker Bay has won over a dozen awards for product innovation, design, and outstanding business practices. Our company was founded on the principles of dependability and customer satisfaction so it is easy to see why there are more than 100,000 Walker Bay boats in use in over 50 countries around the world.



WALKER BAY

— 20 YEARS —

A PASSION FOR DESIGN.



SPACIOUS INTERIORS



MORE STANDARD FEATURES



A SMOOTHER, DRIER RIDE

A BETTER DESIGN. A BETTER BOAT.

At Walker Bay we take the time to consider every aspect as to how our boats might be used. We pay attention to every detail to give our customers a better boating experience. From our biggest deluxe RIB, the Generation 525 with its passenger leaning post that doubles as a boarding handle, to our smallest roll-ups with trim tabs and lifting grips molded into the transom. We go the extra mile to give our customers the best.

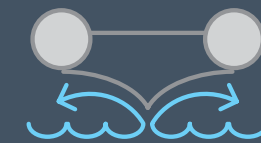

Our curved deep V-Hulls glide through chop and deflect spray downwards.



A wide bow allows for 20% more space and blocks spray for a drier ride.

All of our inflatables are designed to be more spacious and are easy to get in and out from the bow. A wider bow also means less water spray so you and your passengers can enjoy a drier ride. Our unique curved deep V-Hull design provides a sharper entry point while cutting through waves and causes water to be directed back down for a smoother ride in rough conditions and less spray into the boat.

Walker Bay has been recognized for innovation throughout the boating industry:



HISWA



PITTMAN
PRODUCT
AWARD



2006



2008



Montell
POLYOLEFINS

TUBE CONSTRUCTION.

All Walker Bay inflatable boats are built using the finest materials available. They are designed to be incredibly durable and built to perform. Our relentless attention to detail means you can feel confident you own one of the world's finest inflatable boats.

Walker Bay is proud to offer a choice of either name brand ORCA® CSM or Heytex® PVC fabric on all our boats. ORCA® CSM is the best tube fabric available and is engineered to withstand high UV exposure in tropical climates. We guarantee our ORCA CSM tubes for 10 years, the longest warranty in the industry.

German made Heytex® PVC offers a combination of rugged durability and value. It is the best PVC fabric available with extensive real world testing. Our Heytex® PVC tubes incorporate 3-layer welded seams for the strongest seam bond possible and are guaranteed for 5 years.

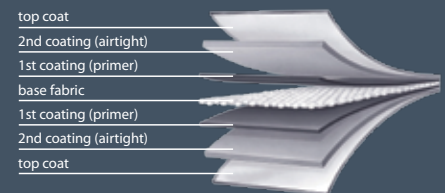
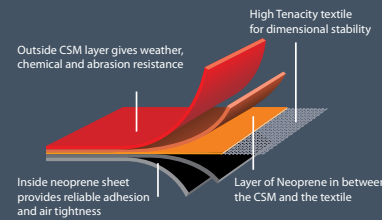

CRAFTSMANSHIP IS THE KEY.



HULL CONSTRUCTION.

Walker Bay uses the most advanced manufacturing processes to create better built hulls that ride better and last longer. Our DuraTech™ fiberglass construction is an environmentally friendly vacuum molding process producing a hull 40% more durable and 30% lighter than traditional fiberglass and our award winning DuraLight™ Genesis hull, the only injection molded polypropylene hull in the world, offers unprecedented durability and impact resistance. Innovative construction methods such as these are what make Walker Bay a leader in the marine industry.



GENERATION. LUXURY REFINED.



GENERATION 525

A NEW LEVEL OF EXCELLENCE.

With elegant European styling and a sporty wide-body frame, the Generation Series will exceed your expectations in both form and function. With detailed attention to hull design and hydrodynamics, Generation outperforms its class with incredible handling. The spacious interior of the open cockpit design affords ample space for cargo and crew. Welcome to the modern age of luxury rigid inflatable boats.

SMOOTHER RIDE. MORE SPACE.

Generation Rigid Inflatable Boats have an extra deep V-Hull for a smoother ride in rough water. The custom built proprietary fuel tank in each Generation makes the ride even smoother by balancing weight distribution in the boat. The forward position of the fuel tank also improves planing performance. The innovative walk through layout makes seating more comfortable and moving around the boat easier.



GENERATION 400



ROOM FOR EXTRAS



GENERATION 525



INNOVATIVE DESIGN. UNSURPASSED QUALITY.

The Generation 525 will exceed your expectations in both function and comfort. Our attention to hull design and engineering along with more standard features have resulted in a truly world class deluxe RIB.

STANDARD FEATURES

- Console w. Passenger Backrest Cushion
- Hydraulic Tilt Steering System
- Deluxe 13" Steering Wheel
- Port and Starboard Boarding Steps
- Removable Leaning Post / Boarding Handle
- Driver's Side Flip-up Bolster Seat
- 5 Stainless Steel Cup Holders
- Heavy Duty Stainless Steel Towing Rings
- 6 Stainless Steel Handrails
- 4 Stainless Steel Pop-up Cleats
- 2 Davit Lifting Point Options
- 7 Stainless Steel Davit Lifting Points
- Low Profile LED Bow Light
- LED Courtesy Lights
- Fresh Water Shower (10G/38L Capacity)
- Deluxe Cushions
- 2 Insulated Cooler Lockers
- Recessed Teak or EVA Boarding Steps

OPTIONAL FEATURES

- Deluxe Boarding Ladder
- Retractable Ski Pole
- Bow Area Deluxe Sun Bed
- Sunbrella Boat Cover

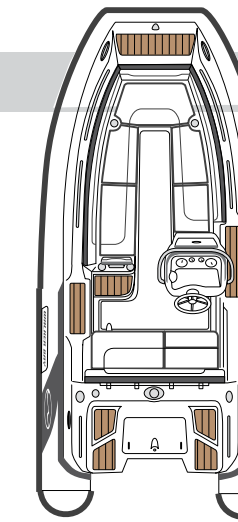

GENERATION 525

| | |
|-----------------|-----------------|
| OVERALL LENGTH | 525 cm / 17' 2" |
| OVERALL BEAM | 254 cm / 8'4" |
| WEIGHT kg/lbs | 527 /1160 |
| MAX PERSONS | 10 |
| MAX LOAD kg/lbs | 1250 / 2750 |
| RECOMMENDED HP | 90 |
| MAXIMUM HP | 115 |



Open layout, more room in the bow



Flip-up bolster seat



Leaning post boarding handle



Console backrest cushion



Retractable ski post (optional)



Integrated LED deck lights

GENERATION 450 / 400



GENERATION 450
(custom cushions shown)

GENERATION 450

The exceptional ride of the 450's deep V-Hull plus the additional 75HP rating results in exhilarating performance. An integrated telescopic ski pole and rear fold down boarding ladder are both standard features on the 450 and 400.

GENERATION 400

The Generation 400 has incredible space and ride that is unprecedented in a 4.0m / 13' Deluxe rigid inflatable. More leg room, additional rear storage and a deep V-Hull provide more comfort and space than any other RIB in its class.

The incredibly smooth ride and ample space in the 400 and 450 Generation are a step above all other luxury rigid inflatables. Both models include a superior layout and ample storage. The standard integrated ski pole and boarding ladder provide more fun on and in the water.

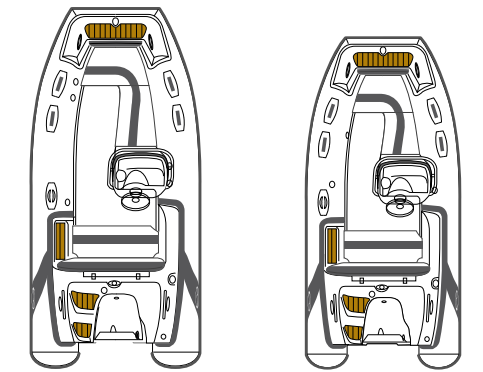

Both the 450 and 400 come standard with an integrated telescopic ski pole and rear fold down boarding ladder.

Deeper V-Hull than other boats its size means Generation handles rough water better and is more comfortable to drive.

Ergonomic console design leaves more legroom for the driver and has more space for mounting accessories.

Push button stern hatch allows plenty of room for dry storage.



GENERATION 400



| | GENERATION 450 | GENERATION 400 |
|-----------------|-----------------|-----------------|
| OVERALL LENGTH | 450 cm / 14' 9" | 400 cm / 13' 1" |
| OVERALL BEAM | 214 cm / 84" | 197 cm / 77" |
| INSIDE LENGTH | 281 cm / 111" | 238 cm / 94" |
| INSIDE BEAM | 106 cm / 42" | 94 cm / 37" |
| TUBE DIAMETER | 51 cm / 20" | 48 cm / 19" |
| TUBE MATERIAL | ORCA CSM | ORCA CSM |
| PERSON CAPACITY | 8 | 7 |
| WEIGHT kg / lbs | 287 / 633 | 259 / 571 |
| SHAFT LENGTH | Long | Long |
| RECOMMENDED HP | 60 | 50 |
| MAXIMUM HP | 75 | 50 |

GENERATION 360 / 340



GENERATION 360

GENERATION 360

The Generation 360 is exceptionally spacious for a boat its size. A walk through interior allows for easy maneuverability and ample storage keeps the cockpit free and clear. The console has more legroom for the driver and room to stretch out a leg while the heavy-duty, high-density cushions provide exceptionally comfortable seating.

GENERATION 340

The Generation 340 is a remarkable boat for its size. It offers the same layout, interior space and smooth ride of the larger Generation 360 while actually being smaller and lighter overall.

The 340 and 360 Generation offer incredible legroom and space for a small deluxe RIB. The walk-through layout, deep V-Hull and integrated custom fit fuel tank in the bow make them drive and feel like a larger RIB while remaining small and compact.

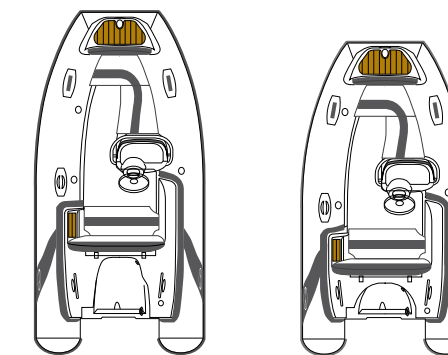

GENERATION 340

GENERATION 360 GENERATION 340

| | | |
|-----------------|------------------|-----------------|
| OVERALL LENGTH | 363 cm / 11' 11" | 342 cm / 11' 3" |
| OVERALL BEAM | 188 cm / 74" | 183 cm / 72" |
| INSIDE LENGTH | 218 cm / 86" | 192 cm / 76" |
| INSIDE BEAM | 85 cm / 34" | 85 cm / 34" |
| TUBE DIAMETER | 48 cm / 19" | 46 cm / 18" |
| TUBE MATERIAL | ORCA CSM | ORCA CSM |
| PERSON CAPACITY | 5 | 5 |
| WEIGHT kg / lbs | 220 / 487 | 210 / 465 |
| SHAFT LENGTH | Long | Long |
| RECOMMENDED HP | 40 | 40 |
| MAXIMUM HP | 40 | 40 |

Bow & stern steps with teak or EVA with no handles or railings to trip over.

Custom V-Fit integrated fuel tank reduces vibration, contributes to earlier planing, and allows more space for storage.

Comfortable flush mount throttle location recessed beside driver so you don't have to stretch when throttling up.

Ergonomic console. Console design leaves more legroom for the driver and has more space for mounting extras.

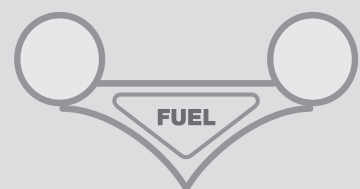

LIGHTWEIGHT CONSOLE RIBs.

ALL THE LUXURY YOU WANT IN A SMALL CONSOLE RIB, AT A WEIGHT AND VALUE YOU WON'T BELIEVE.

Walker Bay offers you more options in a lightweight Console RIB than anyone else. With a choice of 3 different hulls and two different console configurations you are sure to find the right option for you. Choose between the Supertender DuraTech™ deep V-Hull which is perfect for heavy wind chop or bigger water conditions, the super durable Genesis Duralight hull with a medium V and built to hold up to rocks and anything you can throw at it, or the Superlight DuraLight hull with its early planing and super light weight.



SUPERTENDER 365 DELUXE CONSOLE RIB



SUPERLIGHT 310 LIGHT CONSOLE RIB



DELUXE CONSOLE



DELUXE CONSOLE



LIGHT CONSOLE

LIGHTWEIGHT CONSOLE DELUXE RIBs



GENESIS 340 DLX CONSOLE

GENESIS DELUXE CONSOLE

Genesis is incredibly durable and loaded with more features than any other small RIB in its class. With a more comfortable ride than aluminum hulls, the DuraLight hull is the only injection molded polypropylene RIB in the world. The hull is virtually indestructible and comes with a 10 year warranty.



SUPERTENDER DELUXE CONSOLE

Built using DuraTech™ foam-core construction, the Supertender Console RIB has a deeper V than Genesis. It is perfect for rougher conditions and those who prefer a more standard construction material. Supertenders have multiple lifting point options to make them easy to incorporate into any davit system.



Walker Bay's Deluxe Console is designed to offer the ultimate in features, storage and comfort. The proprietary designed console offers more legroom for the driver, creating an exceptionally comfortable riding position. Integrated seat cushions and backrest, storage beneath both the mid and rear seat via removable trays, and a bow locker option, give passengers tons of storage space and the feeling of being in a boat that is twice the price.

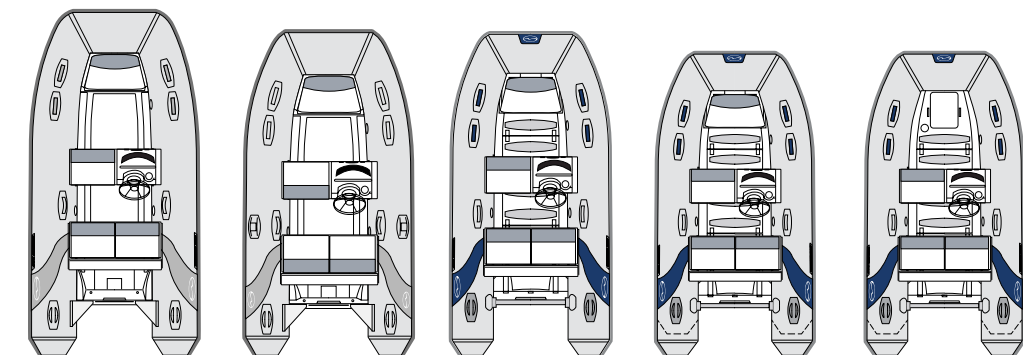

| | SUPERTENDER 365 STX CONSOLE | SUPERTENDER 325 STX CONSOLE | GENESIS 340 DX CONSOLE | GENESIS 310 DX CONSOLE | GENESIS 310 LX CONSOLE |
|-----------------|-----------------------------|-----------------------------|------------------------|------------------------|------------------------|
| OVERALL LENGTH | 365 cm / 12' | 325 cm / 10' 8" | 340 cm / 11' 2" | 310 cm / 10' 2" | 310 cm / 10' 2" |
| OVERALL BEAM | 170 cm / 67" | 163 cm / 64" | 165 cm / 65" | 165 cm / 65" | 165 cm / 65" |
| INSIDE LENGTH | 272 cm / 107" | 236 cm / 93" | 245 cm / 97" | 245 cm / 97" | 245 cm / 97" |
| INSIDE BEAM | 78 cm / 30.5" | 78 cm / 30.5" | 76 cm / 30" | 76 cm / 30" | 76 cm / 30" |
| TUBE DIAMETER | 46 cm / 18" | 43 cm / 17" | 45 cm / 17.5" | 43 cm / 17" | 43 cm / 17" |
| TUBE MATERIAL | ORCA CSM or Heytex PVC | ORCA CSM or Heytex PVC | ORCA CSM or Heytex PVC | ORCA CSM or Heytex PVC | ORCA CSM or Heytex PVC |
| PERSON CAPACITY | 6 | 5 | 5 | 4 | 4 |
| WEIGHT kg / lbs | 106 / 233 | 118 / 259 | 103 / 226 | 101 / 221 | 101 / 221 |
| SHAFT LENGTH | Short / Long | Short | Short | Short | Short |
| RECOMMENDED HP | 20 | 20 | 20 | 15 | 15 |
| MAXIMUM HP | 30 | 30 | 30 | 20 | 20 |

LIGHTWEIGHT CONSOLE RIBs



SUPERLIGHT 310 SLRX CONSOLE

SUPERTENDER LIGHT CONSOLE

The Supertender Light Console Rib is for people looking for a rugged console boat which can take the roughest conditions they need it to, while offering more open space in the boat for gear and passengers.

SUPERLIGHT LIGHT CONSOLE

The Superlight Light Console package is for those looking for the ultimate in lightweight, early planing and affordability in a small console tender. The design is so efficient it can plane two average-sized adults (up to 190lbs each) with a 9.8 engine at a weight totalling 318 pounds, including the engine, boat and all rigging.



Walker Bay's Light Console is designed to provide more space while also being more affordable. The light console includes a flip-up rear seat storage compartment, podium style console with stainless helm and handrail, and overall more space for gear and other belongings in an open boat.

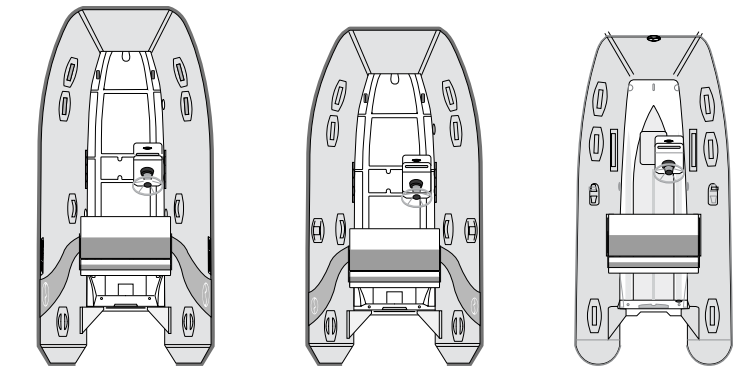

SUPERTENDER 365 ST
LIGHT CONSOLE

SUPERTENDER 325 ST
LIGHT CONSOLE

SUPERLIGHT 310 SLRX
LIGHT CONSOLE

| | SUPERTENDER 365 ST LIGHT CONSOLE | SUPERTENDER 325 ST LIGHT CONSOLE | SUPERLIGHT 310 SLRX LIGHT CONSOLE |
|-----------------|-------------------------------------|-------------------------------------|--------------------------------------|
| OVERALL LENGTH | 365 cm / 12' | 325 cm / 10' 8" | 310 cm / 10' 2" |
| OVERALL BEAM | 170cm / 67" | 163 cm / 64" | 151 cm / 60" |
| INSIDE LENGTH | 272 cm / 107" | 236 cm / 93" | 216 cm / 85" |
| INSIDE BEAM | 78 cm / 30.5" | 78 cm / 30.5" | 68 cm / 27" |
| TUBE DIAMETER | 46 cm / 18" | 43 cm / 17" | 42 cm / 16.5" |
| TUBE MATERIAL | ORCA CSM or Heytex PVC | ORCA CSM or Heytex PVC | ORCA CSM or Heytex PVC |
| PERSON CAPACITY | 5 | 5 | 4 |
| WEIGHT kg / lbs | 138 / 303 | 111 / 244 | 44 / 97 |
| SHAFT LENGTH | Short / Long | Short | Short |
| RECOMMENDED HP | 20 | 20 | 10 |
| MAXIMUM HP | 30 | 30 | 20 |

GENESIS G2. MORE FEATURES. INCREDIBLY DURABLE.



Genesis Open Tenders are the only injection molded polypropylene RIBs in the world. Incredibly durable and feature-loaded with a virtually indestructible hull, they are designed to ride smoother, perform better and last longer.

DuraLight™. A better alternative to hard riding aluminum hulls.

ALUMINUM HULL

- 1-5 Year Warranty
- Impact can permanently dent the hull
- Scratches are visible & allow for corrosion over time
- Extremely jarring & uncomfortable ride
- Lightweight material
- Expensive



DURALITE™ HULL

- 10 Year Warranty
- Incredibly impact resistant
- Scratches are less apparent & do not affect hull integrity
- Extremely forgiving & comfortable ride
- Very lightweight material
- Exceptional value



MORE STANDARD FEATURES

With every Walker Bay boat the true beauty is in the details. Every small point has been considered in the Genesis line of inflatables and it is all packaged together with revolutionary construction.

- Removable tube system
- Removable non-skid floor
- Integrated stainless steel handle on bow storage and seat compartment
- Durable aluminum folding transom
- 3 stainless steel davit lifting points
- Integrated bow eye / front davit lifting point
- Two wheels in the hull™
- Convenient carry handles
- Removable keel strip
- 3-layer reinforced seams
- Integrated bow / seat storage
- One-piece DuraLight™ hull



2008 NMMA AWARD WINNER

GENESIS G2 RIBs



Genesis most impressive feature is performance with exceptional maneuverability and handling. With its deep V-Hull design and DuraLight™ construction it is able to cut through rough water while absorbing vibration for an incredibly smooth ride.

GENESIS DELUXE RIBs

The Genesis Deluxe RIB sets a new standard in small boat design. The deluxe has more storage including a bow locker and large storage hatch in the seat and two large cup holders. With unmatched motoring performance, interior seating, and cockpit space the Genesis Deluxe RIB offers more than any other boat in its class.

GENESIS LIGHT RIBs

Comfort and practicality all in one package. For those concerned with weight and portability, our lightest Genesis hull RIB performs just like the deluxe but is easier to carry. Quick to plane, super durable and easy to store, the Genesis LX comes with a cup holder and a small storage compartment in the seat for valuables. A smart choice for those who want the basics.

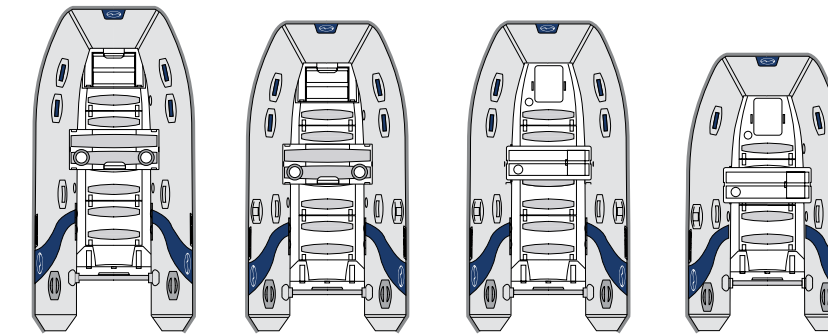

| | 340 DX | 310 DX | 310 LX | 270 LX |
|-----------------|------------------------|------------------------|------------------------|------------------------|
| OVERALL LENGTH | 340 cm / 11' 2" | 310 cm / 10' 2" | 310 cm / 10' 2" | 270 cm / 8' 10" |
| OVERALL BEAM | 165 cm / 65" | 165 cm / 65" | 165 cm / 65" | 162 cm / 64" |
| INSIDE LENGTH | | | | |
| INSIDE BEAM | 76 cm / 30" | 76 cm / 30" | 76 cm / 30" | 76 cm / 30" |
| TUBE DIAMETER | 45 cm / 17.5" | 43 cm / 17" | 43 cm / 17" | 43 cm / 17" |
| TUBE MATERIAL | ORCA CSM or Heytex PVC | ORCA CSM or Heytex PVC | ORCA CSM or Heytex PVC | ORCA CSM or Heytex PVC |
| PERSON CAPACITY | 5 | 4 | 4 | 3 |
| WEIGHT kg / lbs | 62 / 137 | 61 / 135 | 57 / 126 | 50 / 110 |
| SHAFT LENGTH | Short | Short | Short | Short |
| RECOMMENDED HP | 15 | 10 | 10 | 10 |
| MAXIMUM HP | 25 | 15 | 15 | 10 |



Built-in trim tabs promote earlier planing and incorporate launching wheels.

Self-draining bow locker and seat. (Deluxe version)

The Deluxe seat is wide and comfortable with an extra-large storage compartment and 2 cup holders.

A draining, non-skid flat floor has a bilge underneath to keep water away.



DURATECH™. THE ULTIMATE IN PERFORMANCE AND DURABILITY.

Advanced fiberglass moulding is a revolutionary and environmentally friendly vacuum molding process which results in a hull that is 40% more durable and 30% lighter than traditional fiberglass.

40% HIGHER GLASS TO RESIN CONTENT.

Glass (fabric) = strength and more glass means a stronger hull. The DURATECH™ process better controls the application of resin resulting in a much higher strength to weight ratio.

A MORE ENVIRONMENTALLY FRIENDLY PROCESS.

The DURATECH™ closed-mold process lessens styrene emissions and creates a lower emission working environment for operators.

DURATECH™ CONSTRUCTION.

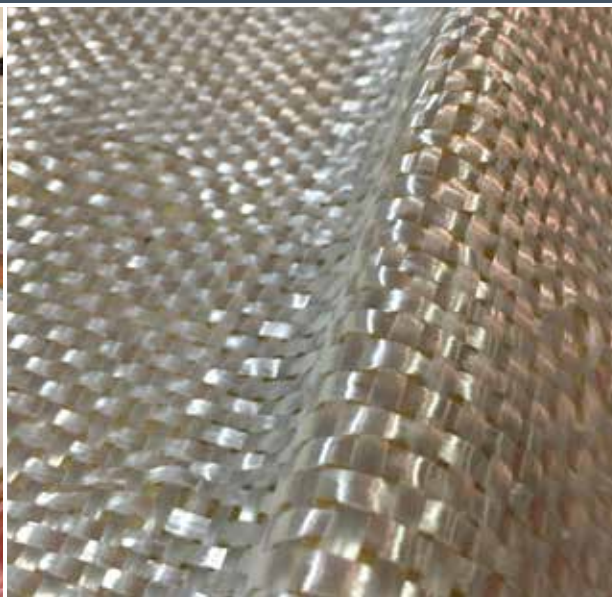

FOAM CORE VS. NO CORE.

A foam core creates incredible structure and is therefore far stronger under impact. The air core pocket on other hulls gives no structure and allows water to penetrate the hull over time increasing weight and delaminating the hull.

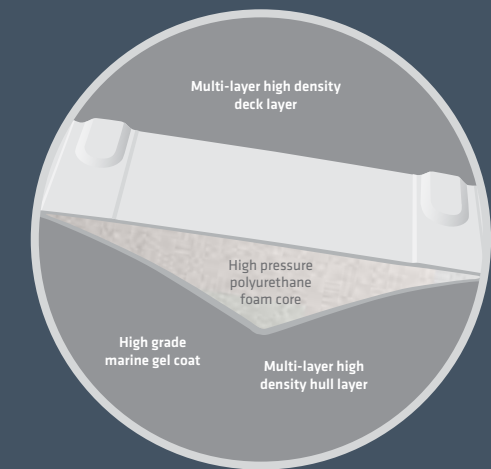

SUPERTENDER RIBs



SUPERTENDER OPEN 365 STX

STX OPEN RIB

The deluxe version of the Supertender comes with an extra-large bow locker that fits a large 6 gallon gas tank or tons of gear. Also included is the deluxe seat with extra storage and two cup holders.

ST OPEN RIB

The ST version is for those who don't require as many features or storage but still want the incredible ride and quality of the Supertender hull. It is lighter in weight and comes with a standard seat including a cup holder and small storage compartment.

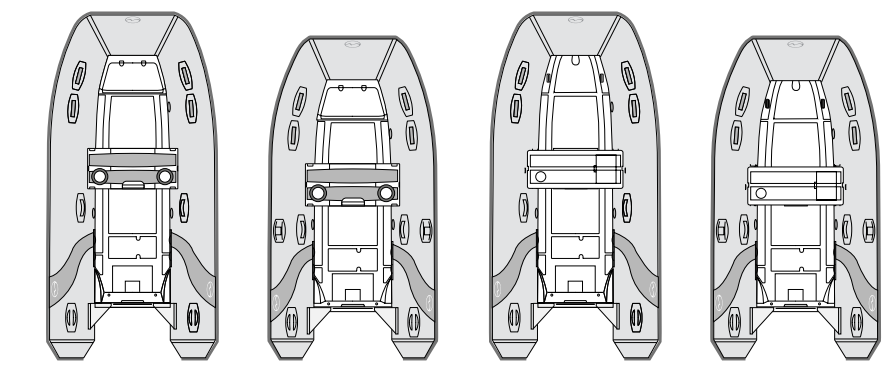

OPEN 365 STX OPEN 325 STX OPEN 365 ST OPEN 325 ST

| | | | | |
|-----------------|------------------------|------------------------|------------------------|------------------------|
| OVERALL LENGTH | 365 cm / 12' | 325 cm / 10' 8" | 365 cm / 12' | 325 cm / 10' 8" |
| OVERALL BEAM | 170 cm / 67" | 163 cm / 64" | 170 cm / 67" | 163 cm / 64" |
| INTERNAL LENGTH | 272 cm / 107" | 236 cm / 93" | 272 cm / 107" | 236 cm / 93" |
| INSIDE BEAM | 78 cm / 30.5" | 78 cm / 30.5" | 78 cm / 30.5" | 78 cm / 30.5" |
| TUBE DIAMETER | 46 cm / 18" | 43 cm / 17" | 46 cm / 18" | 43 cm / 17" |
| TUBE MATERIAL | ORCA CSM or Heytex PVC | ORCA CSM or Heytex PVC | ORCA CSM or Heytex PVC | ORCA CSM or Heytex PVC |
| PERSON CAPACITY | 6 | 5 | 6 | 5 |
| WEIGHT | 106 / 233 | 82 / 181 | 99 / 218 | 76 / 166 |
| SHAFT LENGTH | Short / Long | Short | Short / Long | Short |
| RECOMMENDED HP | 15 | 15 | 15 | 15 |
| MAXIMUM HP | 25 | 25 | 25 | 25 |



Large Bow Locker fits 6 Gallon Gas Tank. (STX Version)

Various internal transom and hull reinforcement points for different davit lifting options.

Deep V-Hull directs spray downward and gives a solid, smooth ride in rough conditions.

The Deluxe seat is wide and comfortable with an extra-large storage compartment and 2 cup holders.



SUPERLIGHT RIBs



SUPERLIGHT OPEN 310 SLR

Light molded seat with integrated storage area and cup holder.

Pronounced chine in hull improves cornering performance and eliminates motor cavitation in turns.

The floor has a channel to run a fuel line so it is neat and out of the way. (SLRX Version)

DuraTech™ construction combines vacuum molding technology with an internal foam core for a stronger and lighter hull.

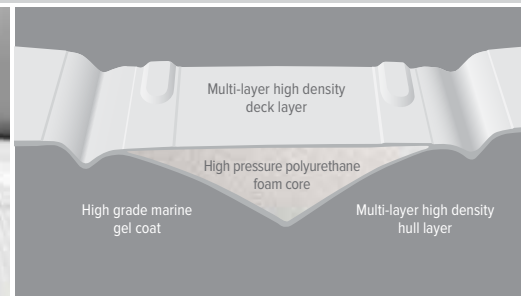

The Superlight RIB is the perfect complement of features and comfort in a small tender. It has more interior space due to a wider bow, and its light weight is achieved through our DuraTech™ molding technique incorporating a high density foam insert to improve stiffness and buoyancy. The innovative floor design has drain channels that keep water away from your feet and allow for improved drainage.

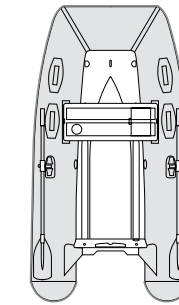
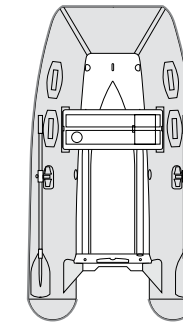
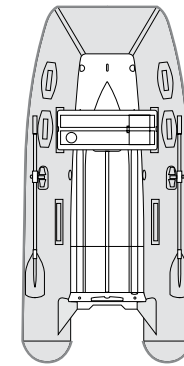

310 SLR / SLRX

270 SLR

240 SLR

| | | | |
|-----------------|------------------------|------------------------|------------------------|
| OVERALL LENGTH | 310 cm / 10 2" | 270 cm / 8' 10" | 240 cm / 7' 11" |
| OVERALL BEAM | 151 cm / 60" | 151 cm / 60" | 151 cm / 60" |
| INSIDE LENGTH | 216 cm / 85" | 176 cm / 69" | 76 cm / 30" |
| INSIDE BEAM | 68 cm / 27" | 68 cm / 27" | 43 cm / 17" |
| TUBE DIAMETER | 42 cm / 16.5" | 42 cm / 16.5" | 42 / 16.5" |
| TUBE MATERIAL | ORCA CSM or Heytex PVC | ORCA CSM or Heytex PVC | ORCA CSM or Heytex PVC |
| PERSON CAPACITY | 5 | 4 | 3 |
| WEIGHT kg / lbs | 44 / 97 | 34 / 75 | 30 / 66 |
| SHAFT LENGTH | Short | Short | Short |
| RECOMMENDED HP | 10 | 10 | 8 |
| MAXIMUM HP | 15 | 15 | 10 |

310 SLRX VS. 310 SLR. WHAT'S THE DIFFERENCE ?

The 310 SLRX has a flat floor with drain channels and a fuel line recess. It is slightly heavier than the 310 SLR but this extra reinforcement is also made in the hull to allow for the light console to be added and to hold larger outboards when used as a console RIB.



ODYSSEY AIR FLOOR



ODYSSEY 270 AF

INFLATABLE FLOOR

High Pressure 11 psi Inflatable Floor: Constructed from two layers of durable copolymer polyester fabric, joined by thousands of dropstitch fibres and inflated to form a lightweight rigid deck, the Air Floor Series offers performance, combined with effortless setup and takedown.

2 SUPERIOR FABRIC CHOICES

Heytex PVC – Walker Bay uses the best name brand PVC in the industry, German made Heytex PVC.

ORCA CSM (short for Chlorosulfonated material) - Walker Bay uses only Pennel ORCA fabric, the industry standard and best choice for superior protection from UV, abrasion, and fading over time.

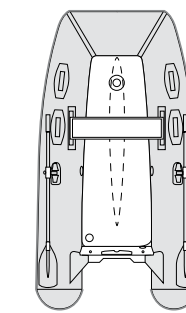
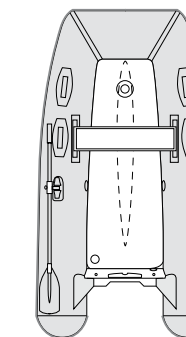
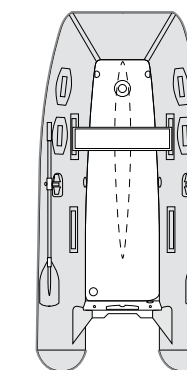

| | 310 AF | 270 AF | 240 AF |
|-----------------|------------------------|------------------------|-----------------|
| OVERALL LENGTH | 310 cm / 10' 2" | 270 cm / 8' 10" | 240 cm / 7' 11" |
| OVERALL BEAM | 154 cm / 61" | 154 cm / 61" | 153 cm / 60" |
| INSIDE LENGTH | 214 cm / 84" | 174 cm / 69" | 156 cm / 62" |
| INSIDE BEAM | 68 cm / 27" | 68 cm / 27" | 68 cm / 27" |
| TUBE DIAMETER | 42 cm / 16.5" | 42 cm / 16.5" | 42 cm / 16.5" |
| TUBE MATERIAL | ORCA CSM or Heytex PVC | ORCA CSM or Heytex PVC | Heytex PVC |
| PERSON CAPACITY | 4 | 3 | 3 |
| WEIGHT | 28 / 62 | 25 / 55 | 22 / 49 |
| SHAFT LENGTH | Short | Short | Short |
| RECOMMENDED HP | 8 | 6 | 5 |
| MAXIMUM HP | 10 | 8 | 6 |



Light and compact, the ultimate "boat in a bag" (bag included).

Oars can be kept externally mounted on tubes or out of the way inside the boat.

Foam core DuraTech™ molded transom with carrying lip.

Wide bow allows for fuel tank to be in the bow out of the way and improves tracking performance.



SPECIFICATIONS

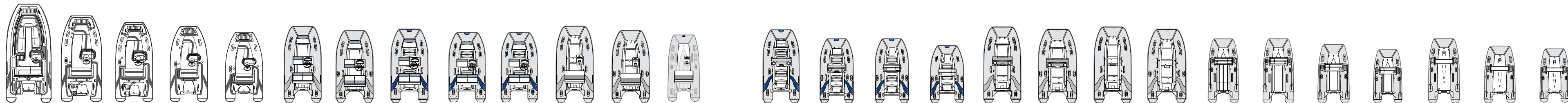

| | GENERATION | | | | | LIGHTWEIGHT DELUXE CONSOLE | | | | | LIGHTWEIGHT CONSOLE | | | | GENESIS | | | | SUPERTENDER | | | | SUPERLIGHT | | | | ODYSSEY | | |
|--------------------------------|------------------|-----------------|-----------------|------------------|-----------------|-----------------------------|-----------------------------|-------------------------------|-------------------------------|-------------------------------|----------------------------------|----------------------------------|-----------------------------------|------------------------|------------------------|------------------------|------------------------|------------------------|------------------------|------------------------|------------------------|------------------------|------------------------|------------------------|------------------------|------------------------|------------------------|------------------------|------------------------|
| | GENERATION 525 | GENERATION 450 | GENERATION 400 | GENERATION 360 | GENERATION 340 | SUPERTENDER 365 STX CONSOLE | SUPERTENDER 325 STX CONSOLE | GENESIS 340 DX DELUXE CONSOLE | GENESIS 310 DX DELUXE CONSOLE | GENESIS 310 LX DELUXE CONSOLE | SUPERTENDER 365 ST LIGHT CONSOLE | SUPERTENDER 325 ST LIGHT CONSOLE | SUPERLIGHT 310 SLRX LIGHT CONSOLE | GENESIS 340 LX | GENESIS 310 DX | GENESIS 310 LX | GENESIS 270 LX | SUPERTENDER 365 STX | SUPERTENDER 325 STX | SUPERTENDER 365 ST | SUPERTENDER 325 ST | SUPERLIGHT 310 SLRX | SUPERLIGHT 310 SLR | SUPERLIGHT 270 SLR | SUPERLIGHT 240 SLR | ODYSSEY 310AF | ODYSSEY 270AF | ODYSSEY 240AF | |
| Overall Length (cm / ft) | 525 cm / 17' 2" | 4.50m / 14' 9" | 4.00m / 13' 1" | 363 cm / 11' 11" | 342 cm / 11' 3" | 365 cm / 12' | 325 cm / 10' 8" | 340 cm / 11' 2" | 310 cm / 10' 2" | 310 cm / 10' 2" | 365 cm / 12' | 325 cm / 10' 8" | 310 cm / 10' 2" | 340 cm / 11' 2" | 310 cm / 10' 2" | 310 cm / 10' 2" | 270 cm / 8' 10" | 365 cm / 12' | 325 cm / 10' 8" | 365 cm / 12' | 325 cm / 10' 8" | 310 cm / 10' 2" | 310 cm / 10' 2" | 270 cm / 8' 10" | 240 cm / 7' 11" | 310 cm / 10' 2" | 340 cm / 11' 2" | 240 cm / 7' 11" | |
| Overall Beam (cm / ft) | 254 cm / 8' 4" | 214 cm / 7' | 197 cm / 6' 5" | 188 cm / 7' 4" | 183 cm / 7' 2" | 163 cm / 6' 4" | 163 cm / 6' 4" | 165 cm / 6' 5" | 165 cm / 6' 5" | 165 cm / 6' 5" | 170 cm / 6' 7" | 163 cm / 6' 4" | 151 cm / 6' 0" | 165 cm / 6' 5" | 165 cm / 6' 5" | 165 cm / 6' 5" | 162 cm / 6' 4" | 170 cm / 6' 7" | 163 cm / 6' 4" | 170 cm / 6' 7" | 163 cm / 6' 4" | 151 cm / 6' 0" | 151 cm / 6' 0" | 151 cm / 6' 0" | 151 cm / 6' 0" | 154 cm / 6' 1" | 165 cm / 6' 5" | 153 cm / 6' 0" | |
| Inside Length (cm / ft) | | | | | | 272 cm / 10' 7" | 236 cm / 9' 3" | 245 cm / 9' 7" | 245 cm / 9' 7" | 245 cm / 9' 7" | 272 cm / 10' 7" | 236 cm / 9' 3" | 216 cm / 8' 5" | 272 cm / 10' 7" | 236 cm / 9' 3" | 236 cm / 9' 3" | 216 cm / 8' 5" | 272 cm / 10' 7" | 236 cm / 9' 3" | 272 cm / 10' 7" | 236 cm / 9' 3" | 216 cm / 8' 5" | 216 cm / 8' 5" | 176 cm / 6' 9" | 214 cm / 8' 4" | 174 cm / 6' 9" | 156 cm / 6' 2" | | |
| Inside Beam (cm / ft) | 156 cm / 61.5" | 106 cm / 3' 6" | 97 cm / 3' 2" | 85 cm / 34" | 85 cm / 34" | 78 cm / 30.5" | 78 cm / 30.5" | 76 cm / 30" | 76 cm / 30" | 76 cm / 30" | 78 cm / 30.5" | 78 cm / 30.5" | 68 cm / 27" | 76 cm / 30" | 76 cm / 30" | 76 cm / 30" | 76 cm / 30" | 78 cm / 30.5" | 78 cm / 30.5" | 78 cm / 30.5" | 78 cm / 30.5" | 68 cm / 27" | 68 cm / 27" | 68 cm / 27" | 68 cm / 27" | 68 cm / 27" | 68 cm / 27" | 68 cm / 27" | 68 cm / 27" |
| Tube Diameter (cm / ft) | 51 cm / 20" | 51 cm / 20" | 48 cm / 19" | 48 cm / 19" | 46 cm / 18" | 46 cm / 18" | 43 cm / 17" | 45 cm / 17.5" | 43 cm / 17" | 43 cm / 17" | 46 cm / 18" | 43 cm / 17" | 42 cm / 16.5" | 45 cm / 17.5" | 43 cm / 17.5" | 43 cm / 17" | 43 cm / 17" | 46 cm / 18" | 43 cm / 17" | 46 cm / 18" | 43 cm / 17" | 43 cm / 17" | 42 cm / 16.5" | 42 cm / 16.5" | 42 cm / 16.5" | 42 cm / 16.5" | 42 cm / 16.5" | 42 cm / 16.5" | 42 cm / 16.5" |
| Total Weight (kg / lbs) | 527 / 1160 | 287 / 633 | 259 / 571 | 220 / 487 | 210 / 465 | 106 / 233 | 118 / 259 | 103 / 226 | 101 / 221 | 101 / 221 | 138 / 303 | 111 / 244 | 44 / 97 | 62 / 137 | 61 / 135 | 57 / 126 | 50 / 110 | 106 / 233 | 82 / 181 | 99 / 218 | 76 / 166 | 44 / 97 | 44 / 97 | 34 / 75 | 30 / 66 | 28 / 62 | 25 / 55 | 22 / 49 | |
| Airtight Compartments | 5+1 | 5 | 3 | 3 | 3 | 3+1 | 3+1 | 3 | 3 | 3 | 3+1 | 3+1 | 3+1 | 3 | 3 | 3 | 3 | 3+1* | 3+1* | 3+1* | 3+1* | 3+1 | 3 | 3 | 3 | 2+2 | 2+2 | 2+1 | |
| Tube Material | ORCA CSM | ORCA CSM | ORCA CSM | ORCA CSM | ORCA CSM | ORCA CSM or Heytex PVC | ORCA CSM or Heytex PVC | ORCA CSM or Heytex PVC | ORCA CSM or Heytex PVC | ORCA CSM or Heytex PVC | ORCA CSM or Heytex PVC | ORCA CSM or Heytex PVC | ORCA CSM or Heytex PVC | ORCA CSM or Heytex PVC | ORCA CSM or Heytex PVC | ORCA CSM or Heytex PVC | ORCA CSM or Heytex PVC | ORCA CSM or Heytex PVC | ORCA CSM or Heytex PVC | ORCA CSM or Heytex PVC | ORCA CSM or Heytex PVC | ORCA CSM or Heytex PVC | ORCA CSM or Heytex PVC | ORCA CSM or Heytex PVC | ORCA CSM or Heytex PVC | ORCA CSM or Heytex PVC | ORCA CSM or Heytex PVC | ORCA CSM or Heytex PVC | ORCA CSM or Heytex PVC |
| Capacity | | | | | | | | | | | | | | | | | | | | | | | | | | | | | |
| Passengers | 10 | 8 | 7 | 5 | 5 | 6 | 5 | 5 | 4 | 4 | 5 | 5 | 4 | 5 | 4 | 4 | 3 | 6 | 5 | 6 | 5 | 5 | 5 | 4 | 3 | 4 | 3 | 3 | |
| Max Payload (kg / lbs) | 1250 / 2750 | 866 / 1910 | 753 / 1660 | 599 / 1317 | 599 / 1317 | 886 / 1950 | 777 / 1709 | 605 / 1331 | 575 / 1264 | 575 / 1264 | 886 / 1950 | 777 / 1709 | 67 / 1357 | 620 / 1364 | 640 / 1408 | 620 / 1364 | 520 / 1144 | 950 / 2090 | 857 / 1886 | 950 / 2090 | 857 / 1886 | 617 / 1357 | 603 / 1327 | 518 / 1140 | 420 / 924 | 650 / 1430 | 540 / 1188 | 420 / 924 | |
| Outboard Data | | | | | | | | | | | | | | | | | | | | | | | | | | | | | |
| Motor Shaft | Long | Long | Long | Long | Long | Short / Long | Short | Short | Short | Short | Short / Long | Short | Short | Short | Short | Short | Short | Short / Long | Short | Short / Long | Short | Short | Short | Short | Short | Short | Short | Short | Short |
| Max. Power (kw / hp) | 86 / 115 | 56 / 75 | 38 / 50 | 30 / 40 | 30 / 40 | 23 / 30 | 22 / 30 | 22 / 30 | 15 / 20 | 15 / 20 | 22 / 30 | 22 / 30 | 15 / 20 | 18.75 / 25 | 11.25 / 15 | 11.25 / 15 | 8 / 10 | 18.75 / 25 | 18.75 / 25 | 18.75 / 25 | 18.75 / 25 | 11.25 / 15 | 11.25 / 15 | 11.25 / 15 | 8 / 10 | 8 / 10 | 6 / 8 | 4.5 / 6 | |
| Recommended Power (kw / hp) | 68 / 90 | 45 / 60 | 38 / 50 | 30 / 40 | 30 / 40 | 15 / 20 | 15 / 20 | 15 / 20 | 11.25 / 15 | 11.25 / 15 | 15 / 20 | 15 / 20 | 8 / 10 | 11.25 / 15 | 8 / 10 | 8 / 10 | 8 / 10 | 11.25 / 15 | 11.25 / 15 | 11.25 / 15 | 11.25 / 15 | 8 / 10 | 8 / 10 | 8 / 10 | 6 / 8 | 6 / 8 | 4.5 / 6 | 4 / 5 | |
| Hull Construction | Hand Lamination | Hand Lamination | Hand Lamination | Hand Lamination | Hand Lamination | DuraTech™ | DuraTech™ | DuraLight™ | DuraLight™ | DuraLight™ | DuraTech™ | DuraTech™ | DuraTech™ | DuraLight™ | DuraLight™ | DuraLight™ | DuraLight™ | DuraTech™ | DuraTech™ | DuraTech™ | DuraTech™ | DuraLight™ | DuraLight™ | DuraLight™ | DuraLight™ | DuraLight™ | DuraLight™ | DuraLight™ | DuraLight™ |
| Fuel Tank Capacity (ltr / gal) | 125 ltr / 32 gal | 57 ltr / 15 gal | 45 ltr / 12 gal | 42 ltr / 11 gal | 42 ltr / 11 gal | | | | | | | | | | | | | | | | | | | | | | | | |

All dimensions & weights indicated have a tolerance of plus or minus 3% or 5% respectively. Weights as measured for lifting purposes do not include removable seat and oars. Oars weight is 3.3lbs / 1.5kg and seat weight is 7.5lbs/3.4kg respectively. Published weights are for PVC model.



WALKER BAY

walkerbay.com

walkerbay.com is the place for all your questions and communication on Walker Bay products. There is extensive product information, videos, and owner downloads available. Go to walkerbay.com for more information.

To find your nearest authorized Walker Bay dealer, please consult our website..
Walker Bay® is a registered trademark of Walker Bay Boats LLC, Copyright© Walker Bay Boats.