

A

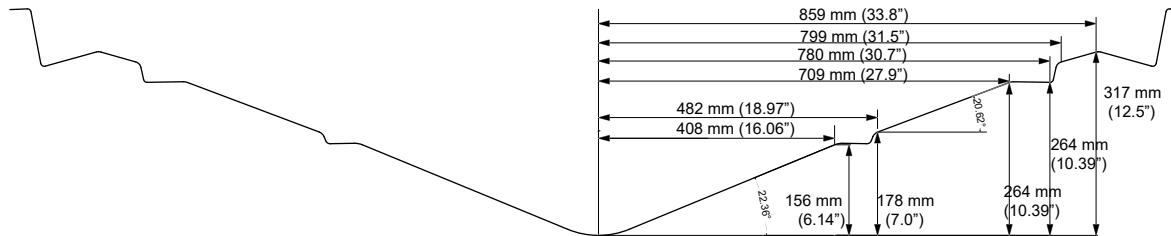

B

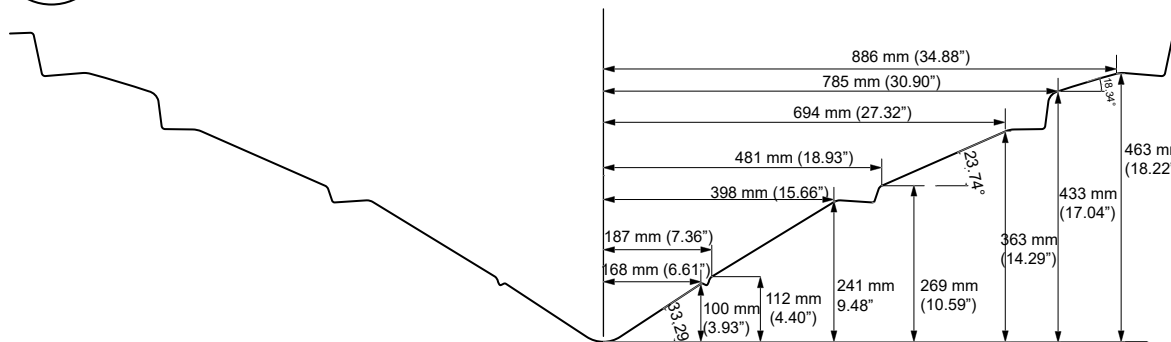

CAUTION

Use caution when positioning and securing boat on chocks, cradles, bunks and when trailering. Avoid positioning the boat in a manner where point loading may occur on lifting strakes. A bunk style trailer is recommended for towing. Excessive point loading or failure to adequately support hull may damage the hull. Damage resulting from not properly supporting the hull or motor is not covered under warranty.