

Venture 14

LIFTING POINTS & CHOCKS



WALKER BAY

Side View

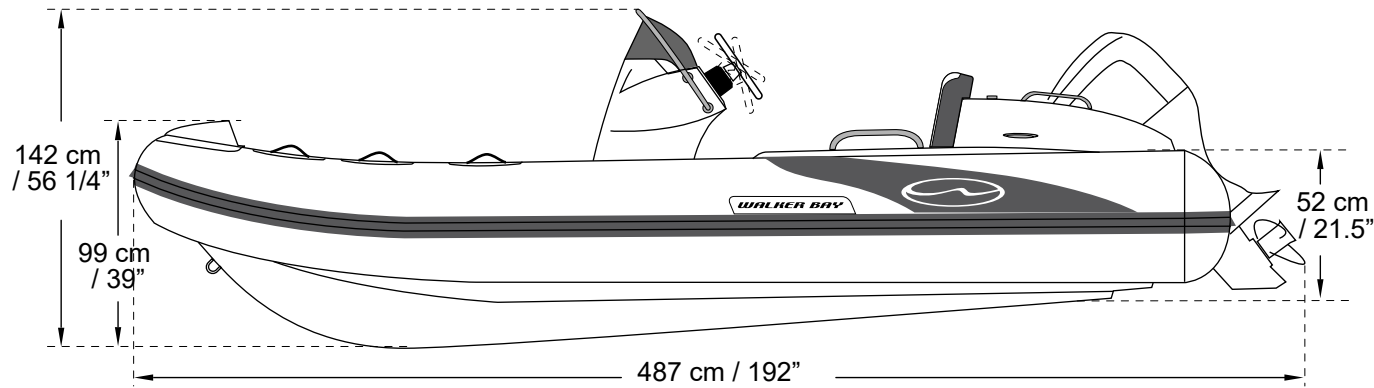

Rear View

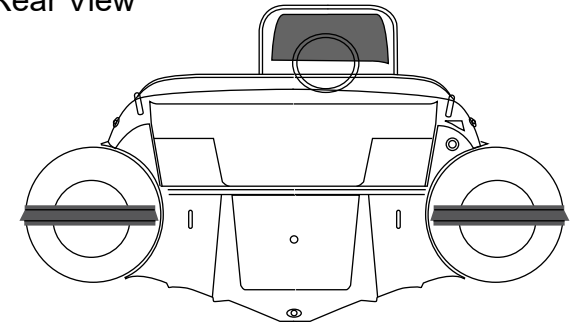

Top View

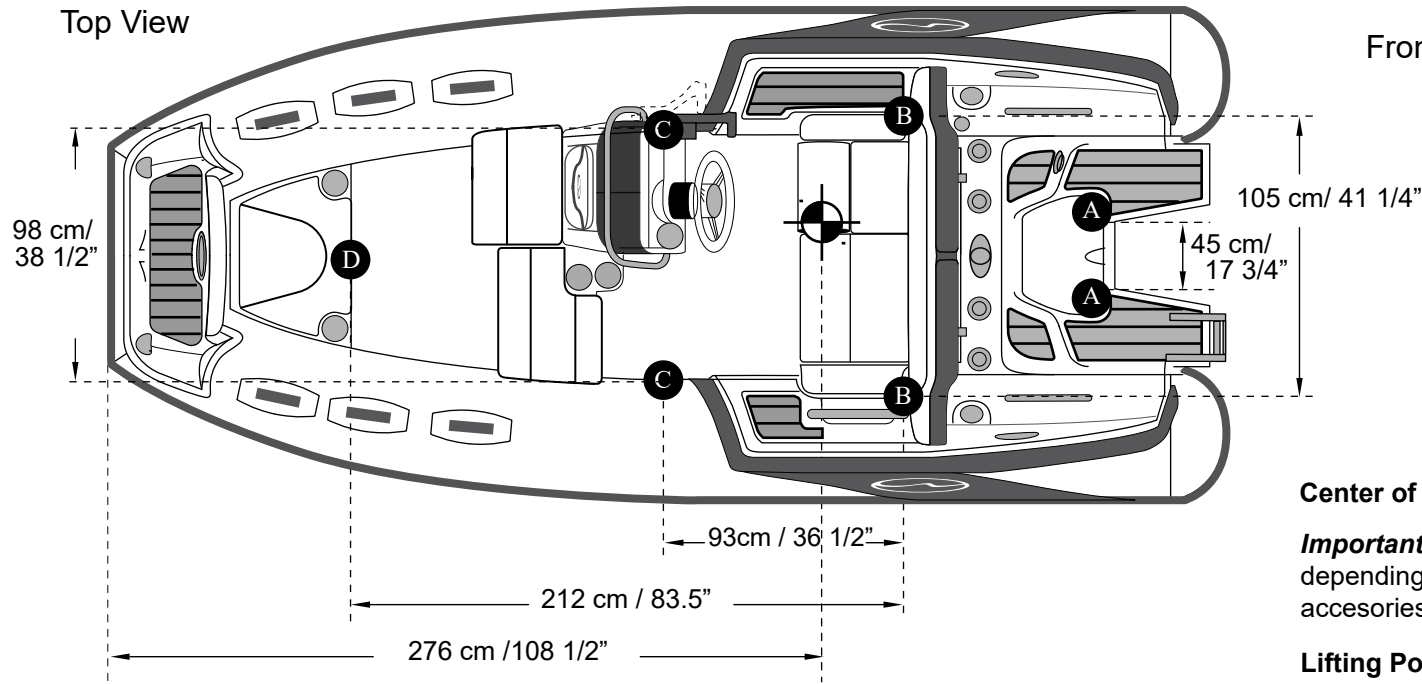

Front View

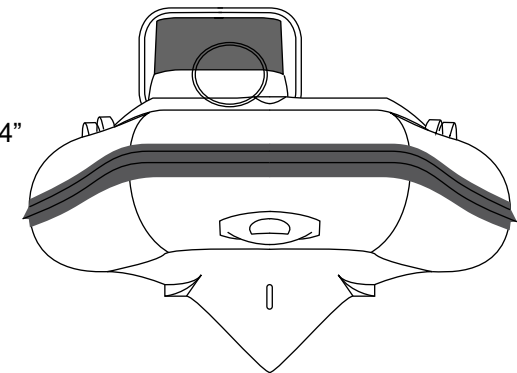

Center of Balance



Important Note: Center is approximate and will vary depending on weight of motor, quantity of fuel, water, accessories and gear in boat.

Lifting Points **A B C D**

Lifting point options: A+D, A+C, B+D, B+C
Do not attempt to lift with A+B, C+D.

Information subject to change without notice.

Venture 14

LIFTING POINTS & CHOCKS



WALKER BAY

Side View

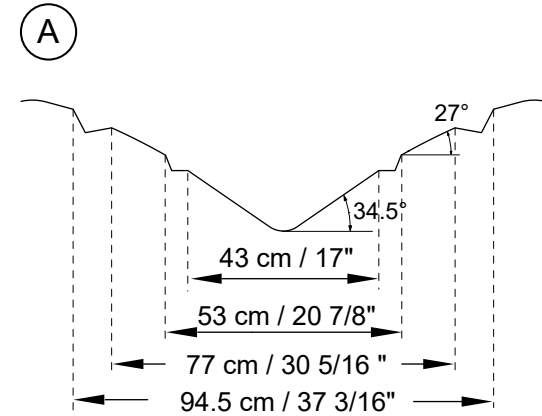
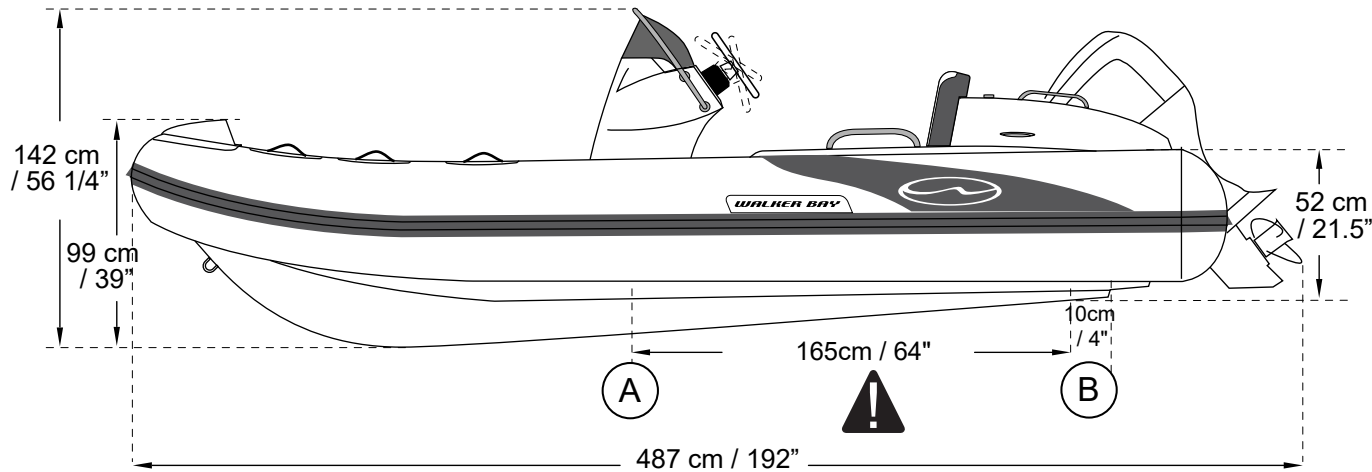

Top View

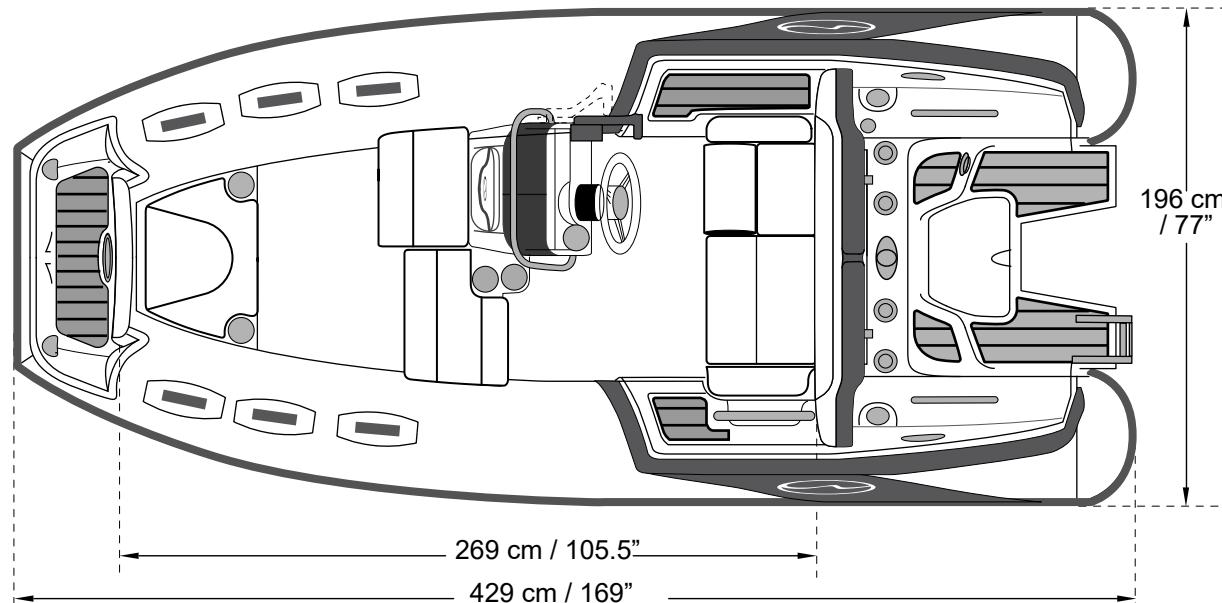

Position bunks here.

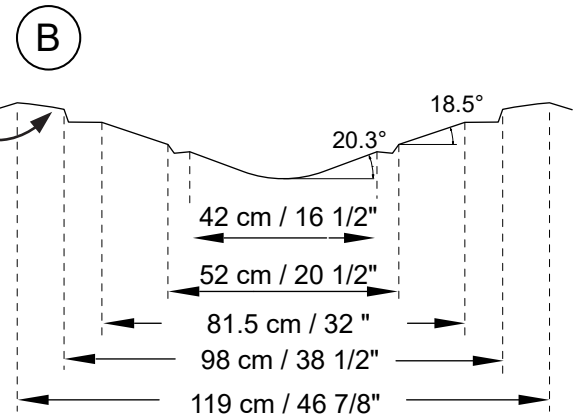

CAUTION

Use caution when positioning and securing boat on chocks, cradles, bunks and when trailering. Avoid positioning the boat in a manner where point loading may occur on lifting strakes.

A bunk style trailer is recommended for towing. Bunks should be positioned on the outer side of the outer most lifting strakes.

Excessive point loading or failure to adequately support hull may damage the hull.

Damage resulting from not properly supporting the hull or motor is not covered under warranty.

Information subject to change without notice.