

Generation 400

SPECIFICATIONS & MAXIMUM CAPACITIES

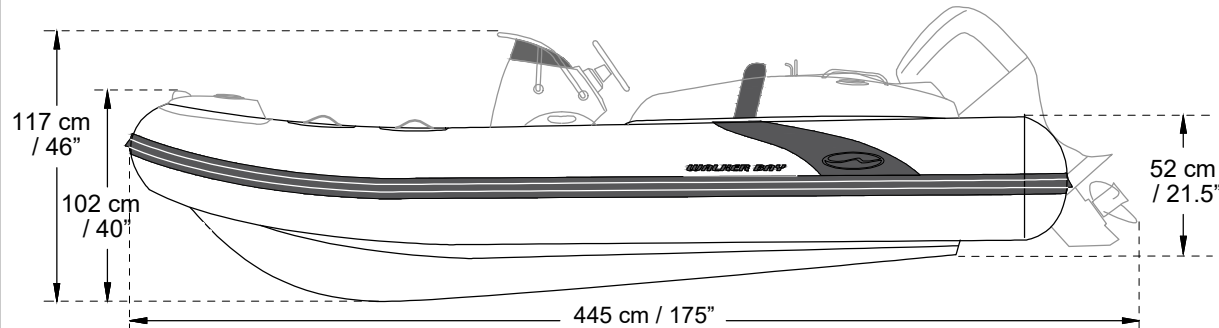

WALKER BAY



Side View

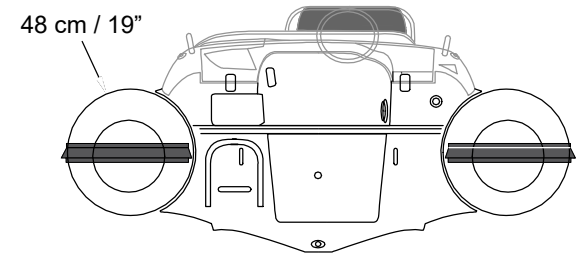

Rear View

Top View

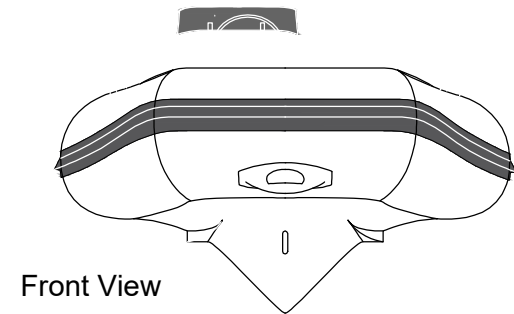
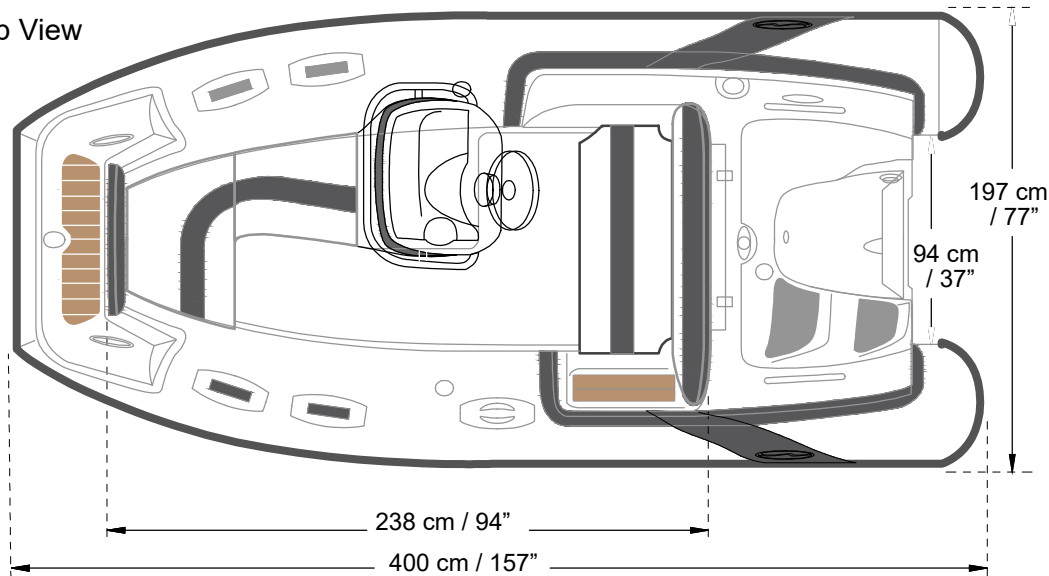

Front View

SPECIFICATIONS AND MAXIMUM CAPACITIES (Subject to change without notice. Tolerances: Dimensions +/- 3% Weight +/- 5%)

MODEL	ISO 6185 PART	ISO 6185		ISO 6185		ISO 6185		ISO 6185		ISO 6185		ISO 6185		ISO 6185		Wet Weight (Approximate)		AIR CHAMBERS		PSI / BAR				
		KG	LB	#	KG	LB	KG	LB	Maximum	Recommended	Maximum Speed		KG	LB	KG	LB	PSI	BAR						
									KW	HP	KW	HP	KT	MPH	Km/h									
GENERATION 400	3	C	753	1660	7	525	1072	L	132	335	38	50	38	50	30	34	55	259	571	354	900	3	3.5	0.24

Generation 400

LIFTING POINTS & CHOCKS



WALKER BAY

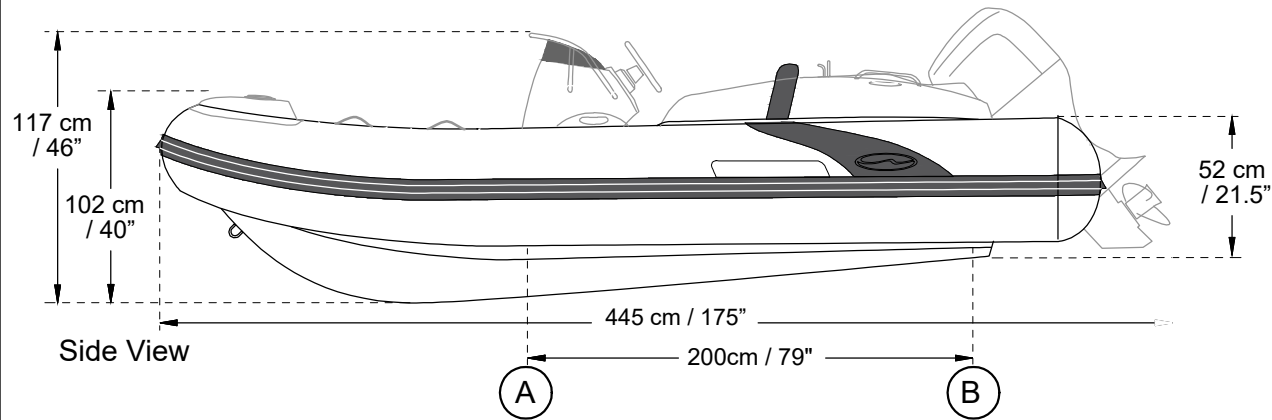

Area Reinforced for Additional Lifting Point*.
 *On 2017 Models only.
 Requires installation of Lifting Eye by Dealer.

Distance Between Lifting Points

Top View

