

Odyssey 365ST/STX Console Long & Short Shaft

365STX C Long Shaft Shown

SPECIFICATIONS & MAXIMUM CAPACITIES



WALKER BAY

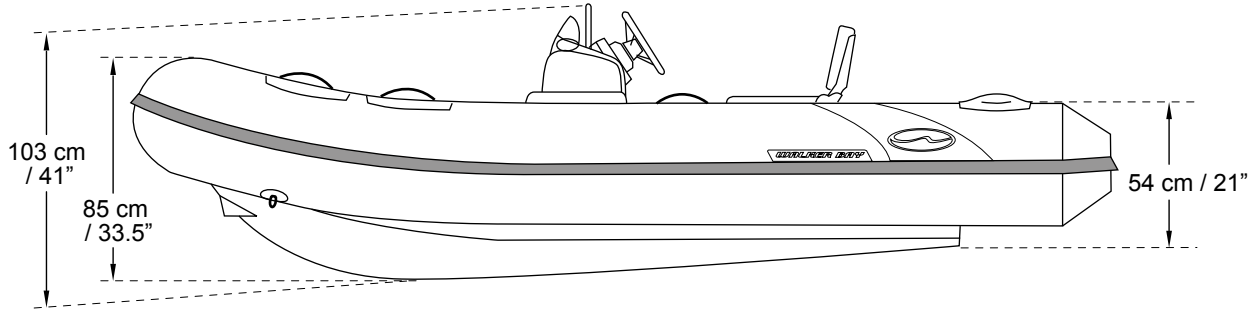

Side View

Top View

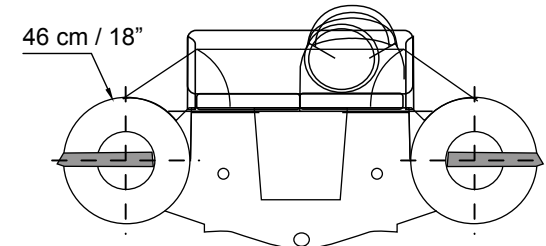
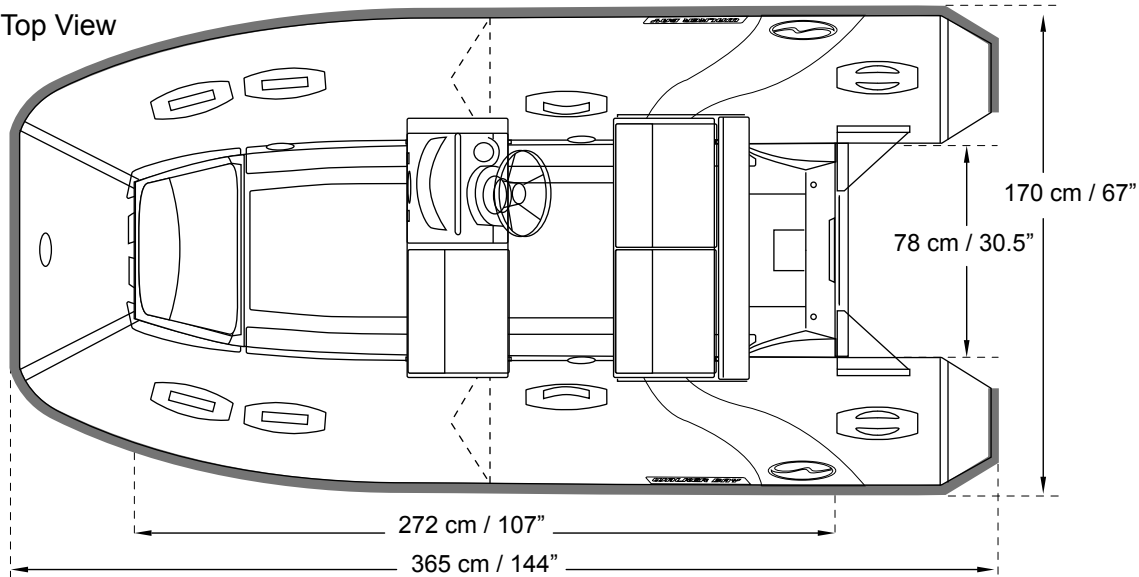

Rear View

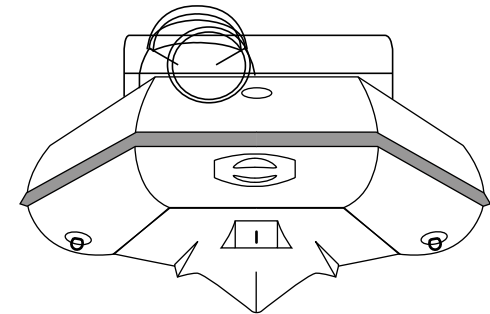

Front View

SPECIFICATIONS AND MAXIMUM CAPACITIES (Subject to change without notice)

Tolerances: Dimensions +/- 3% Weight +/- 5%

MODEL	ISO 6185 PART	ISO 6185	Person with Load		#	Person		Person with Load					20HP 15kW		Dimensions										AIR CHAMBERS		Dimensions											
			KG	LB		KG	LB	Length	KW	HP	KG	LB	KT	KG	LB	A	B	C	D	E	a	b	PSI	BAR	X		Y		Z									
			IN	MM		IN	MM	IN	CM	KG	LB	IN	CM	KG	LB	IN	MM	IN	MM	IN	MM	IN	MM	IN	MM	IN	MM	IN	MM									
365STX C (L)	3	C	886	1950	5	391	860	L	23	30	80	175	30	241	530	144	3.65	67	1.70	41	103	146	321	18	46	107	2.72	30.5	78	3	3.5	0.25	116	2.95	39	101	41	103
365STX C (S)	3	C	886	1950	5	391	860	S	23	30	80	175	30	238	523	144	3.65	67	1.70	41	103	143	314	18	46	106	2.69	30.5	78	3	3.5	0.25	115	2.92	39	101	41	103
365ST C (L)	3	C	886	1950	5	391	860	L	23	30	80	175	30	233	512	144	3.65	67	1.70	41	103	138	303	18	46	107	2.72	30.5	78	3	3.5	0.25	116	2.95	39	101	41	103
365ST C (S)	3	C	886	1950	5	391	860	S	23	30	80	175	30	230	506	144	3.65	67	1.70	41	103	135	297	18	46	106	2.69	30.5	78	3	3.5	0.25	115	2.92	39	101	41	103