



WALKER BAY®

275 RID™ Assembly Instructions

Part No. 1000130023 v.2 Lscsep01



PARTS LIST

(Specifications and contents subject to change without notice)

Description	Part #
A. RID Track	2000010520
B. Capacity Plate	10053
C. Repair Kit (with valve wrench)	3000030046
D. Bolts* (10-32 x 5/8")	11043
E. Rubberback Washers* (#12)	11076
F. Nylock Nuts* (10-32)	11067
G. RID Tube	3001020351
H. Pump	1000330002

*Extra bolt, washer & nut included for convenience.

web: www.walkerbay.com email: info@walkerbay.com

RETROFIT RID TRACK ASSEMBLY INSTRUCTIONS FOR NON RID READY BOATS

Tools you will need:

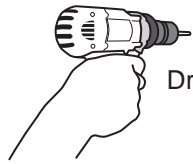

Drill with bit #11 [3/16]

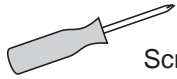

Screwdriver

1

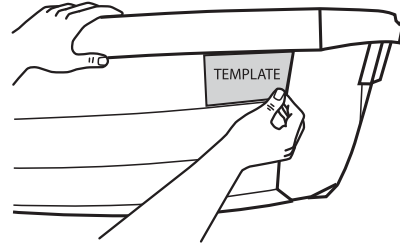

Cut out template on corner of page. Align port (left) template with outside of port gunwale lip and first rib on aft edge.

2

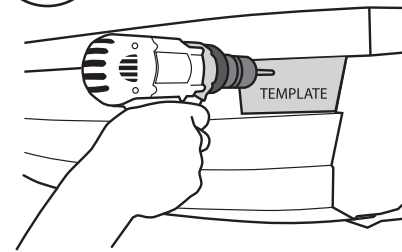

Using a drill gun & bit #11, drill first hole. Be careful to drill hole perpendicular to hull.

3

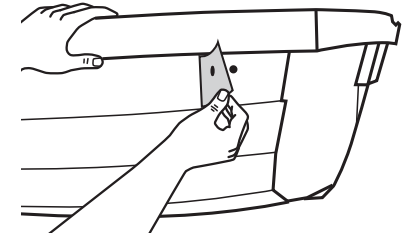

Remove paper template.

4

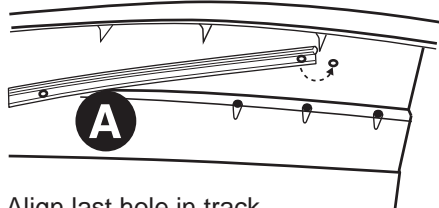
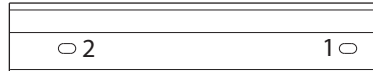

Align last hole in track with hole drilled on boat.

5

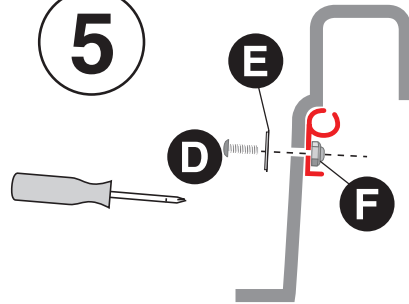

Insert bolt and washer from inside boat. From outside, attach nut loosely, do not tighten yet.

6

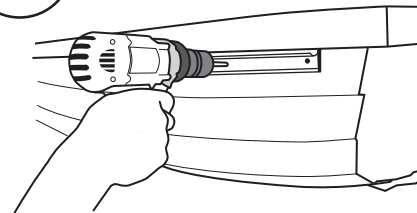

Align track with gunwale lip and drill remaining holes to match pre-drilled holes in track. Insert bolts & washers for each hole, attaching nut loosely.

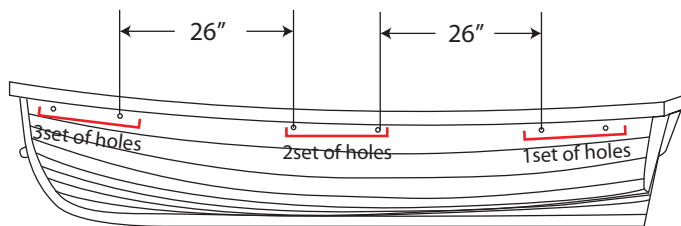

Distance between the set of holes to drill.

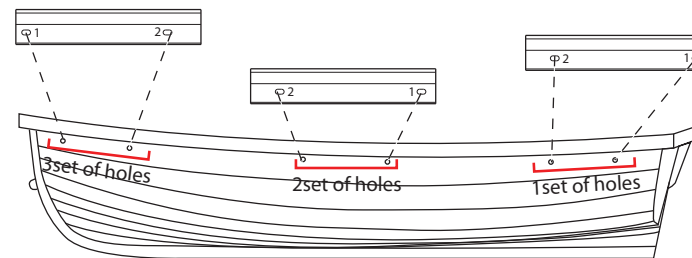

positioning for the tracks

NOTE: the distance of the holes of the track varies in the third track in both sides of the hull

RID TRACK ASSEMBLY INSTRUCTIONS FOR RID READY BOATS

1

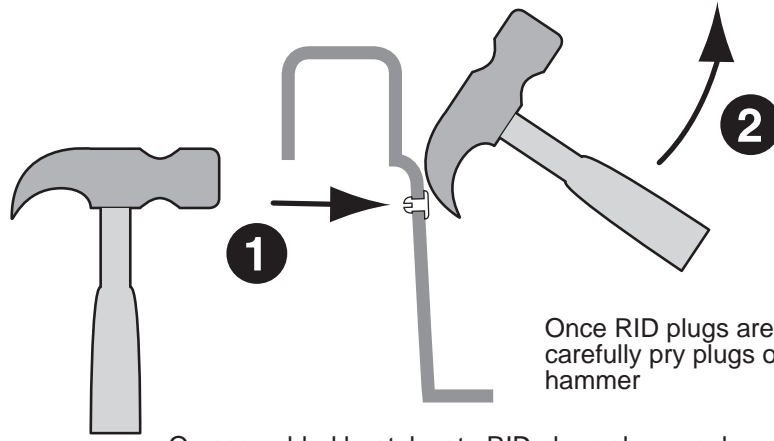
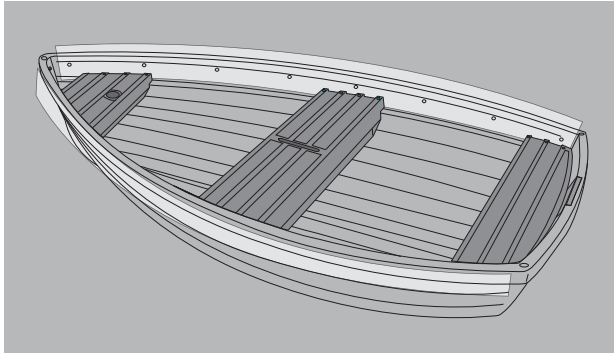

Once RID plugs are dislodged, carefully pry plugs out with claw of hammer

On assembled boat, locate RID plugs along each side of the hull. Gently tap RID plugs out with a hammer.

2

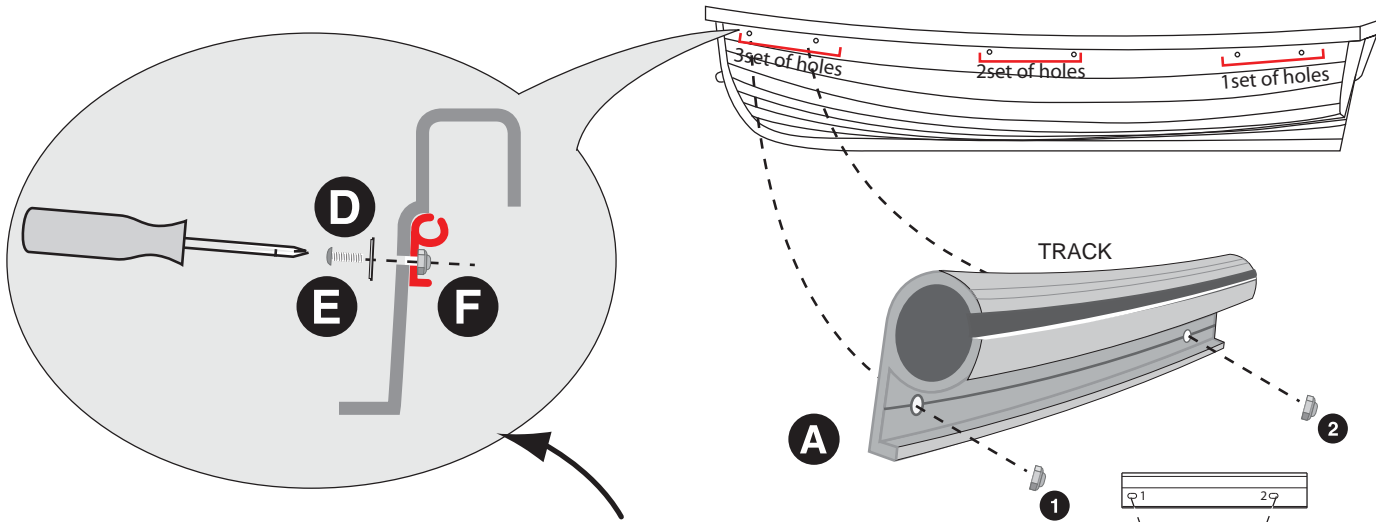

To secure track to hull, insert bolt and washer from inside of hull and nut from outside of hull.

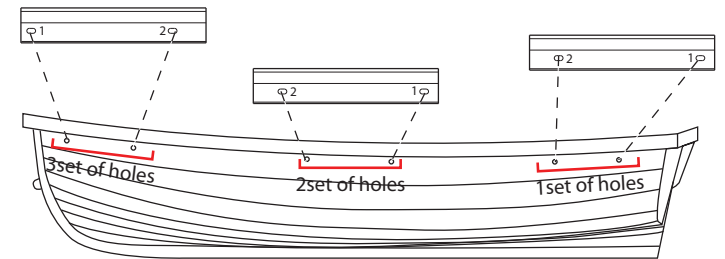

positioning for the tracks

NOTE: the distance of the holes of the track varies in the middle track in both sides of the hull

TUBE INSTALLATION INSTRUCTIONS

NOTE:

Before you begin the installation process, make sure your boat hull is completely stabilized. The boat should not be able to move freely in any direction.

Before installing tube note tube's **serial number** located in this * position on the tube. You will need it to complete your **Warranty Registration Card**.

If possible, have one person feed tube into track, while other person pulls tube.

If alone, try sliding tube on with boat upside down.

- 1 Begin by sliding BOTH sides of tube halfway down first track set. (as shown in Illustration).

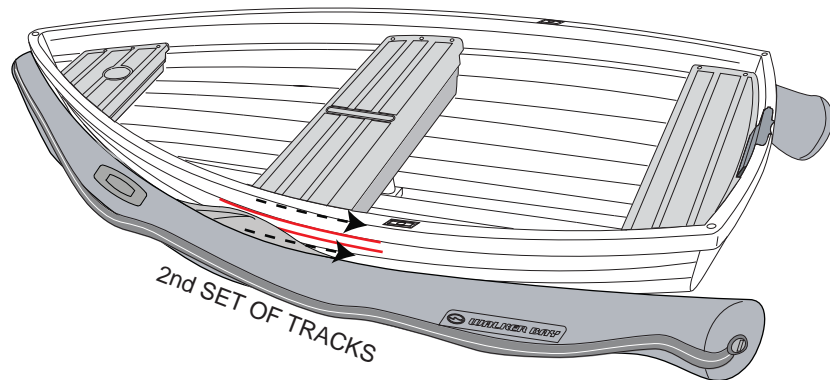
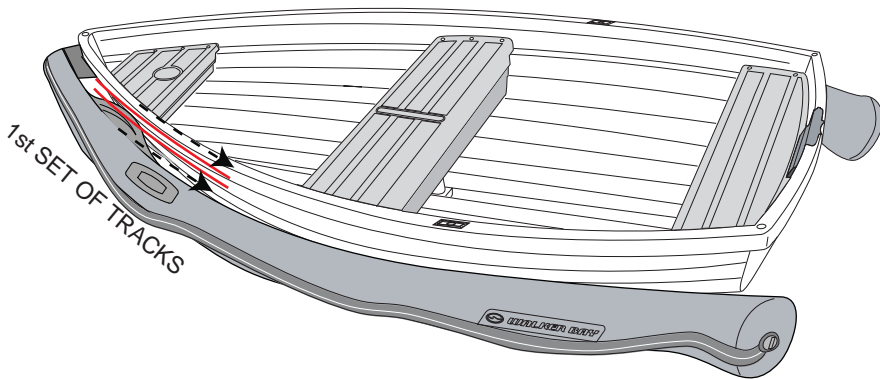

Partially inflate tube (1/4 full) and apply liquid soap and water to track runner on tube to help feed tube into track with greater ease.

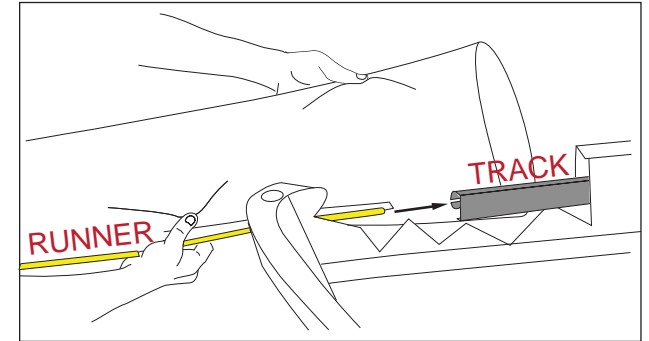

DO NOT FORCE TUBE INTO TRACK.
Use care when feeding tube runner into track.

- 2 After installing the first set of tracks proceed with the mid set of tracks. Don't forget to use liquid soap for a easier sliding



Make sure the front of the tube is well aligned with the front of the hull.

3

After installing the second set of tracks proceed with the front set of tracks.

4

Using wrench provided in repair kit, hand tighten each valve. DO NOT OVER TIGHTEN VALVE.

Inflate chambers in sequence shown until wrinkles disappear.

5

Peel backing from capacity plate and apply new plate on inside of the stern, over top of existing plate.

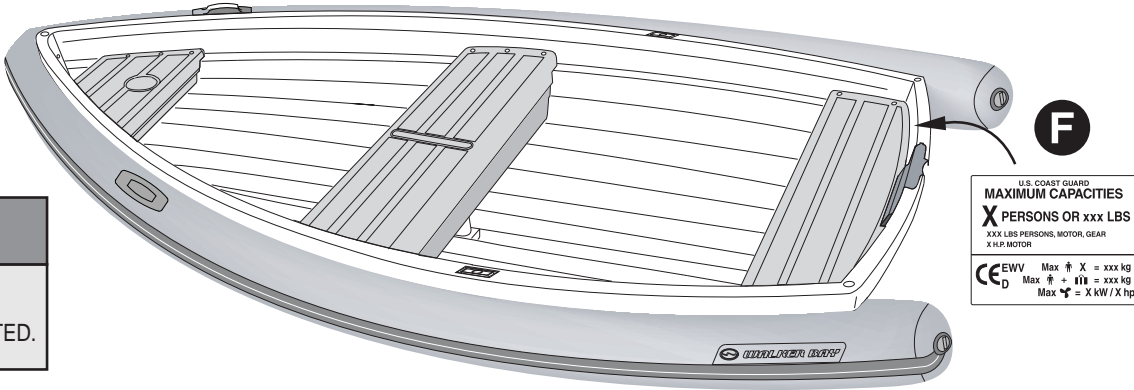
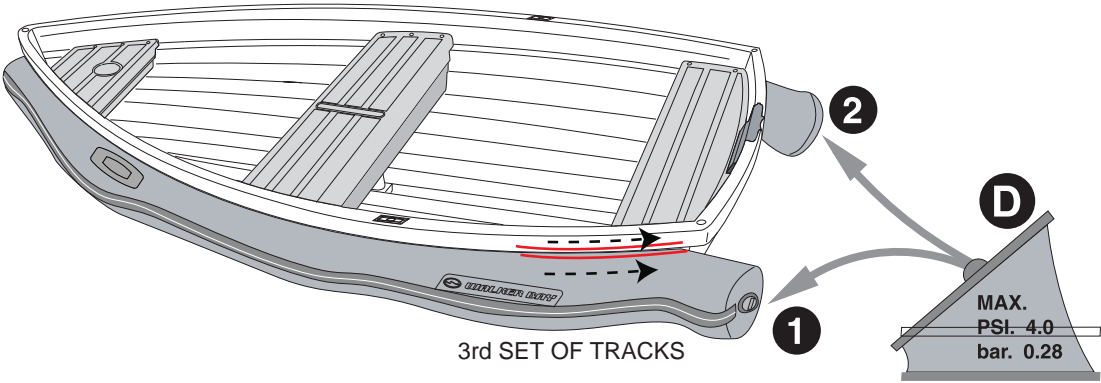

! WARNING

TUBE PROVIDES FLOTATION AND STABILITY.
CAPACITY LABEL IS VOID UNLESS TUBE IS INFLATED.

MAINTENANCE

TUBES - After use, rinse boat with mild liquid soap and fresh water, rinse away sand and debris.

Apply 303 Aerospace Protectant at least once per season to protect tube from UV (ultra violet) rays. Walker Bay® recommends 303 because it is free of silicone oils, waxes, glycerin, or petroleum distillates unlike many other protectants. 303 leaves a like-new, non-oily, anti-static finish that does not attract dust. 303 can be purchased through the manufacturer's website: www.303products.com

VALVES - Tighten air valves several times per season. Loose valves may result in air leaks or loss of pressure in the tube. Tighten valves with the tool provided in the repair kit.

DO NOT OVERTIGHTEN VALVES.

Valve replacement should be done by a trained professional. Contact your dealer to replace valves.

CAUTION

Do not use oily or abrasive substances.

Do not use products that contain: phosphates, chlorine, solvents, non-biodegradable or petroleum based products.

Do not use Armor All® automotive cleaning agent and preservative on tube.

Read labels and instructions carefully to avoid products that could be harmful to polypropylene, PVC or other plastics.

Use only diluted citrus-based cleaners. They are excellent for marine cleaning purposes, and safe to use. Full strength citrus-based cleaners can discolor PVC.

Use household cleaners sparingly and do not discharge them into waterways.

Avoid contact of the tubes' fabric with hazardous or harmful materials such as: battery acid, oil, gasoline, vinyl preserving agents, or alcohol based cleaning solutions, waxes, or solvents.

Avoid contact of sharp or abrasive objects with the tube. They can puncture the tube.

Do not mix cleaners and work in a well ventilated area.

STORAGE

Avoid storing the tube in sunlight.

For longterm or winter storage you may remove the tube.

If you store the boat with the tube attached you must release some air pressure as the air inside the tube expands and contracts with temperature variation.

Rinse boat with mild soap and fresh water after use. Rinse away sand or debris.

Dry boat before storing to prevent accumulation of mould.

Store boat in a cool and dry place.

CAUTION

Risk of fire. Do not store fuel, fuel tanks, fuel lines or any fuel related components in direct sunlight. Read Owner's Manual provided with your outboard motor for storage information.

Avoid storing boat in water when not in use to prevent contact with hazardous chemicals due to pollution, abrasion from foreign objects and accumulation of marine growth.

Use a boat cover or storage bag. Avoid unnecessary exposure of the tubes to direct sunlight. If a bag or cover is not provided with your boat, accessory covers are available. For information contact your local dealer.

Do not store boat where it may come in contact with sharp or abrasive objects.

Do not store boat where rodents may have access to it, they can chew through the tube's fabric creating a leak.

TUBE REPAIRS

For repairs, parts, or service contact your local dealer.

SMALL TEARS - CUTS - PUNCTURES

Tears, leaks, or punctures less than 0.5 inches or 1 cm can be repaired with the repair kit provided.

1. Prepare a round patch no less than 3 inches or 7 centimeters in diameter.
2. Clean the patch and the area surrounding the leak with Isopropyl Alcohol. **IMPORTANT:** patch and tube must be clean or the patch may not adhere properly.
3. To contain excess glue, use masking tape to tape off the area around the patch. Excess glue will discolor.
4. Apply 3 thin, even coats of repair kit adhesive to both the surface of the tube and the patch. Wait 5 minutes between each coat.
5. After the 3rd coat, wait 10-15 minutes before applying the patch. Use a hand roller to apply the patch evenly. Pay special attention to the edges.
6. Wait 24 hours before re-inflating tube. Inflate air chamber(s) to working pressure and check water-tightness and/or air-tightness before using.

FINDING SMALL LEAKS

1. Mix a solution of 4 cups of fresh water and 1 cup of mild **non-anti-bacterial** liquid soap. Do not use a spray bottle containing any household cleaners.
2. Inflate tube approximately to working pressure.
3. Spray the soapy solution over suspected area of leak.
4. Look for air bubbles. Bubbles around an air valve indicate it is probably loose. Use the tool included in the repair kit and gently tighten valve. Bubbles on the surface of the tube indicate a puncture or leak.
5. Repair the tube by following the procedure for SMALL TEARS - CUTS - PUNCTURES or contact your local dealer.

LARGE REPAIRS TO SKIN - SEAMS - BULKHEADS

CAUTION

For large tears or repairs to seams or bulkheads it is recommended that the tube be returned to your local dealer for repair by a trained professional.



RID RETROFIT TEMPLATE
STARBOARD (RIGHT) SIDE



RID RETROFIT TEMPLATE
PORT (LEFT) SIDE